



samsara

Vehicle Gateway

INSTALL GUIDE — HEAVY DUTY (J1708)

What you'll need:



1x



2x



2x

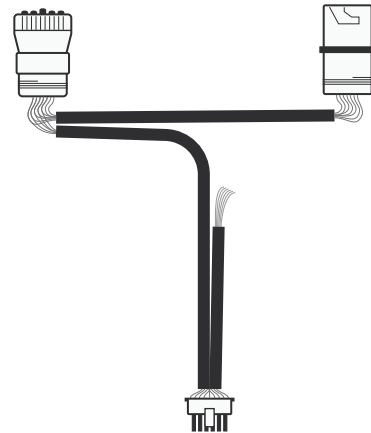

1x

Questions? samsara.com/support

1 Locate vehicle's diagnostic port and detach it from its original location.

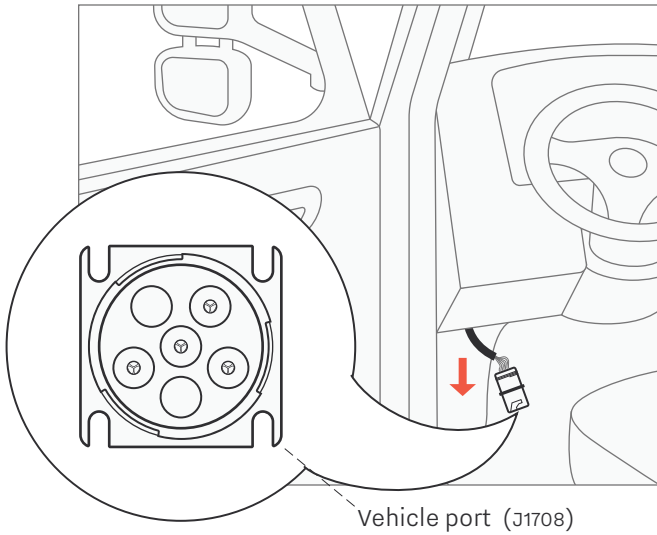

2 Connect the Samsara Cable. Vehicle's diagnostics remain accessible via the unconnected port.

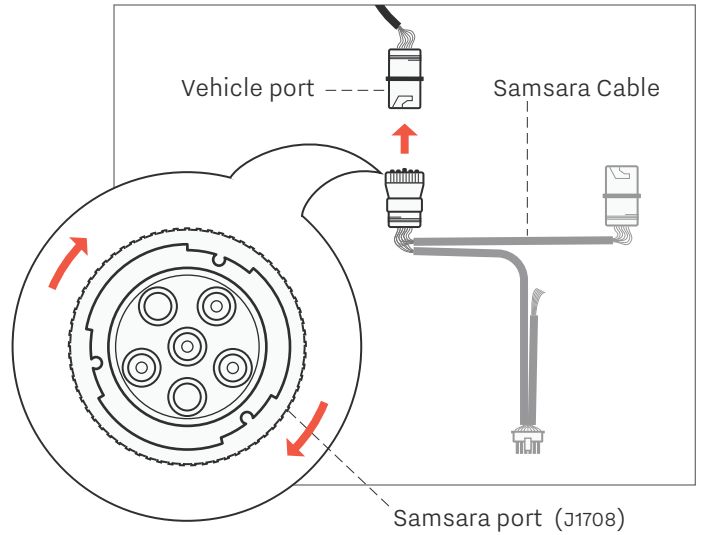

3 Fasten unconnected diagnostics port to vehicle's original port location.

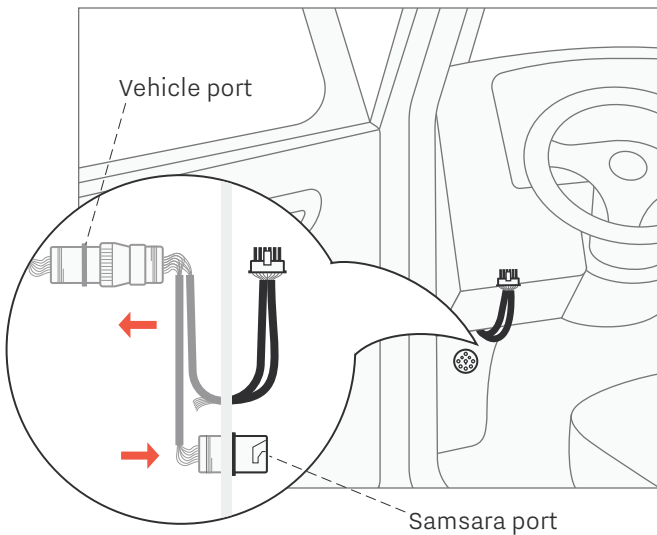

4 Plug the Samsara Cable gateway connector into the Gateway. It will click when fully inserted.

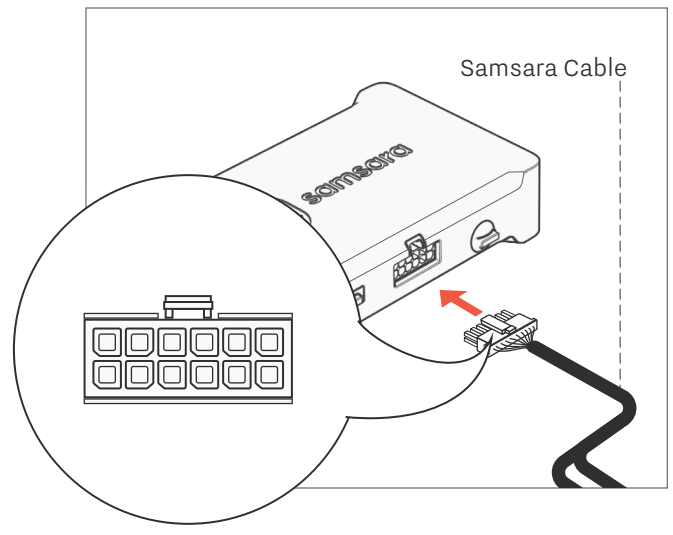

5 Verify the Gateway indicator light turns green. This could take 1-3 minutes.

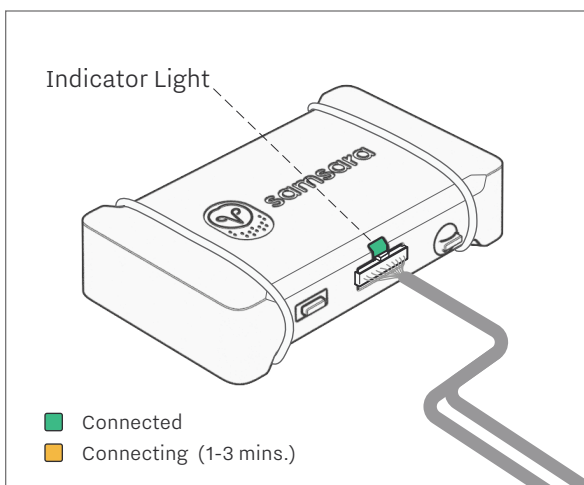

6 Fasten connected Gateway in a secure position behind the dashboard using zip ties.

